

RoHS

REV.	ECN NO.	LOCATIONS	DESCRIPTION	DATE	DESIGN
A0			原始版本(INITIAL EDITION)		

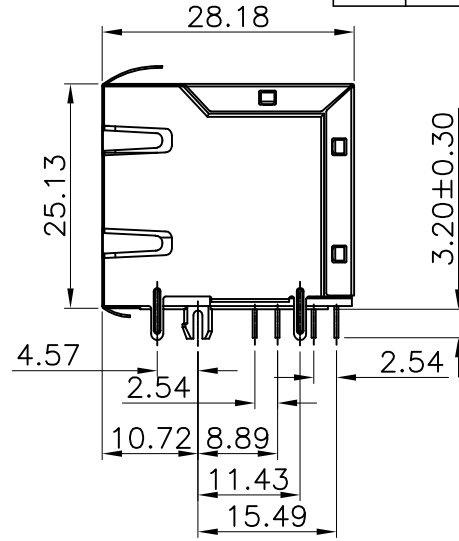
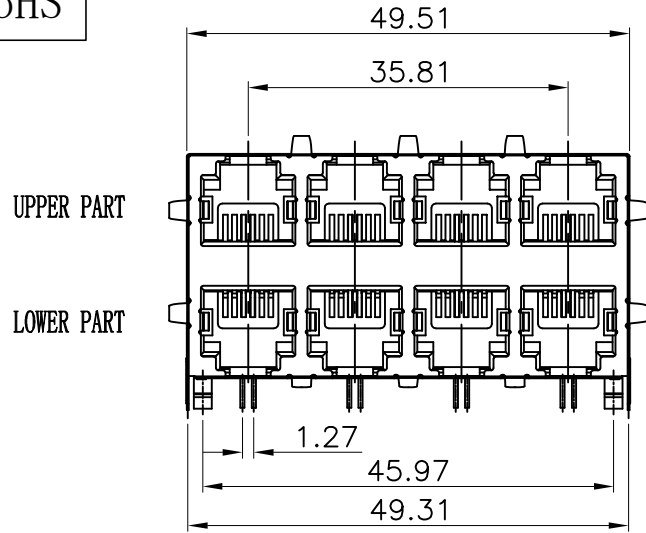

NOTE:

ELECTRICAL:

- VOLTAGE RATING: 125V AC.
- CURRENT RATING: 1.5A.
- CONTACT RESISTANCE: 30 mΩ MAX.
- INSULATION RESISTANCE: 500 MΩ MIN @ 500V DC.
- DIELECTRIC STRENGTH: 1000V AC 50Hz or 60Hz, 1MIN.

MECHANICAL:

- INSERT MATERIAL: PBT BLACK
- CONTACT MATERIAL: DIAMETER 0.46mm C51000(QSn4-0.3) PHOSPHOR BRONZE GOLD (G.F)PLATING OVER NICKEL.
- SHELL:C2680 NICKEL PLATING
- MATING/UNMATING FORCE: 2.2KG.F MAX.
- RETENTION STRENGTH: 7.7KG.F MIN BETWEEN JACK AND PLUG.
- OPERATING LIFE: 750 CYCLES MIN.

ENVIRONMENTAL:

- STORAGE: -40°C ~ +85°C RELATIVE HUMIDITY<70%.
- OPERATION: -40°C ~ +85°C.

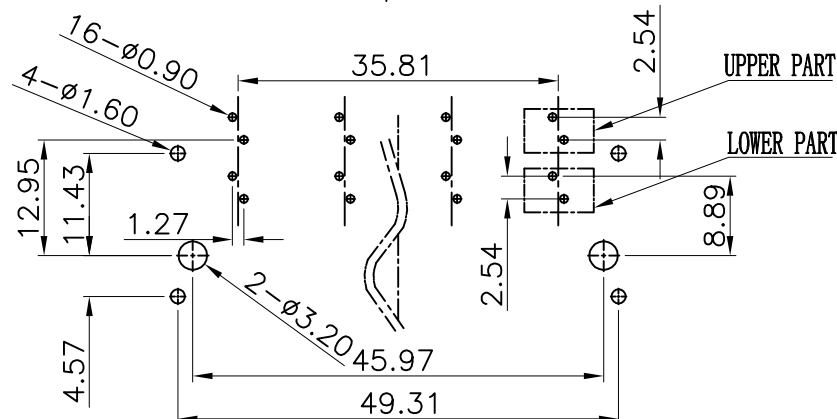
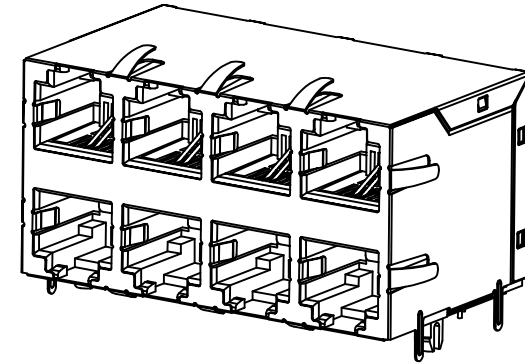
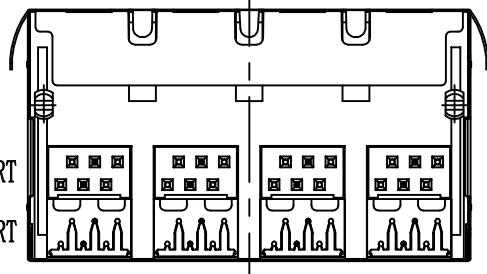

PC Board Layout Component Side Shown  
PC Board Thickness=1.6mm  
Tolerance±0.05

 UNIT: mm [inch] TOLERANCE: X.X ±0.35 X.XX ±0.25 X.XXX ±0.15 Angle ±3.0° SCALE:1:1 SIZE:A4	 深圳市盈创利电子有限公司 Shenzhen Ying Chuang Li Electronics co., LTD.	
	DESIGN:	PART NAME: RJ11 2x4 三面带弹 底面有弹6P2C
	CHECKED:	PART NO. 5B11-211C
	APPROVED:	DRAW NO.
SHEET NO. 1 OF 1		